

*Randol Mill Hazardous Road
Overtopping Mitigation Project
Community Meeting on Design Plans
The meeting will begin at 1:00 PM*

May 18, 2024

Project Manager: Berton Guidry, PE, CFM

Project Engineer: Mark C. Galvan, PE - Halff Associates

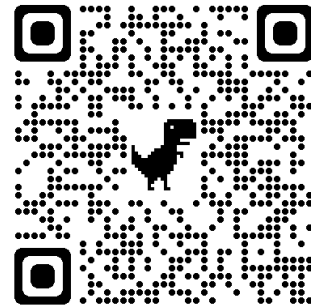

Randol Mill Hazardous Road Overtopping Mitigation Project

Project Purpose

- Stormwater Overtops Roadway During Intense Rainfall Events creating a life safety concern
- Construct Improvements to Mitigate the Stormwater Overtopping the Roadway

Project Location

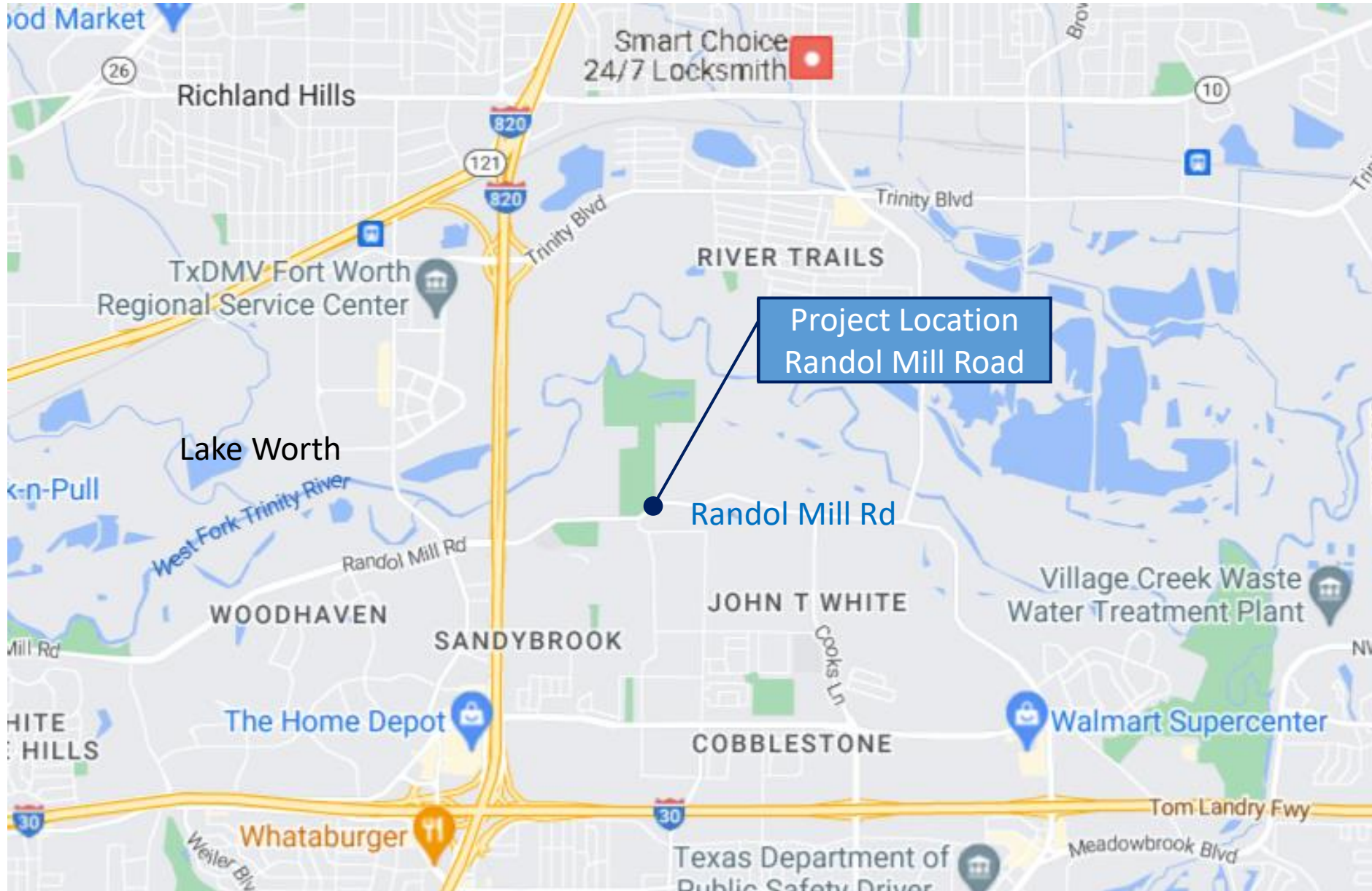

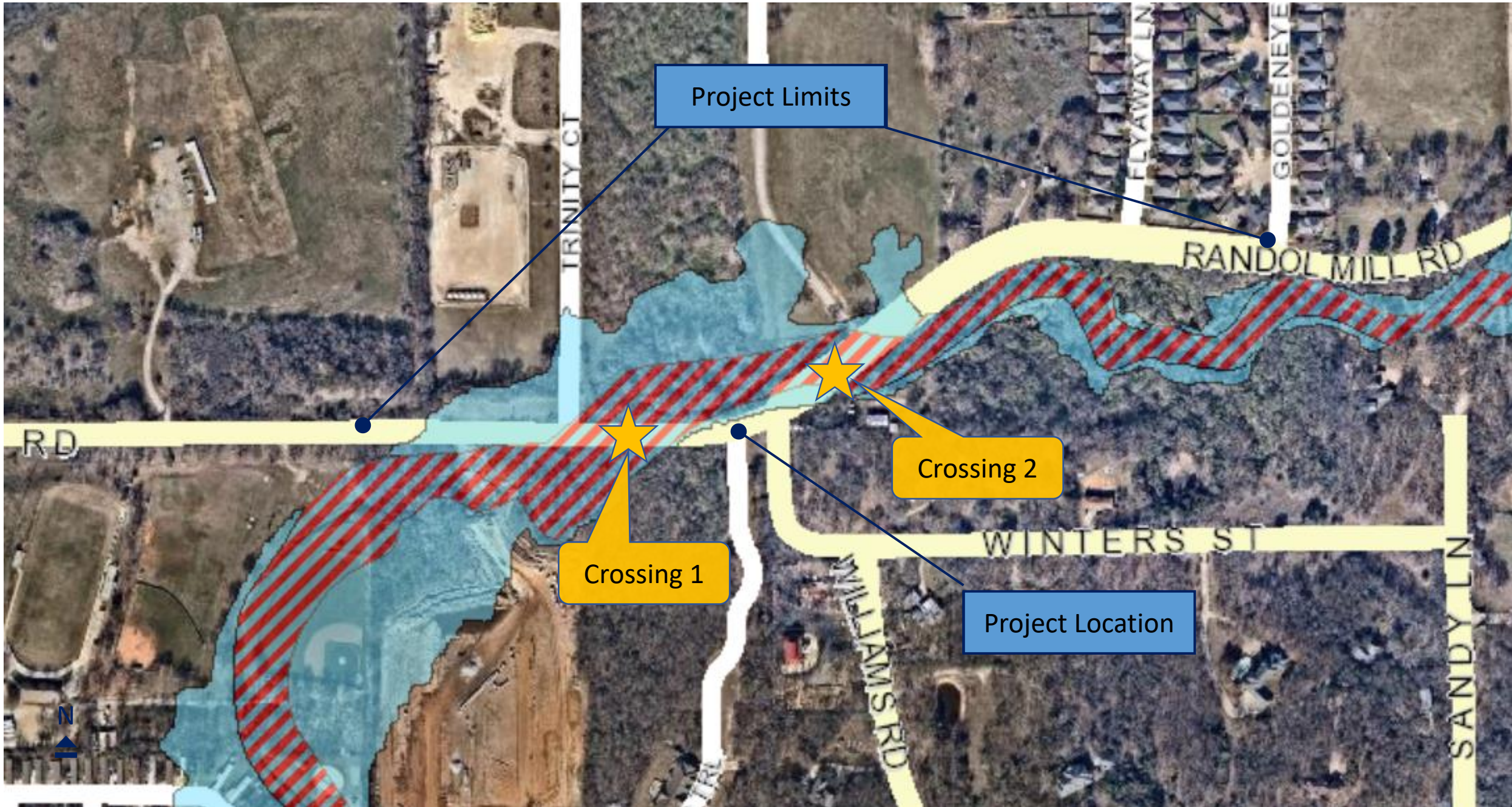

Project Limits

Crossing 1

Crossing 2

Project Location

Roadway Flooding



Stormwater
Overtopping
Roadway and
Rescue Boat

Abandoned Car
Due to Storm
Waters

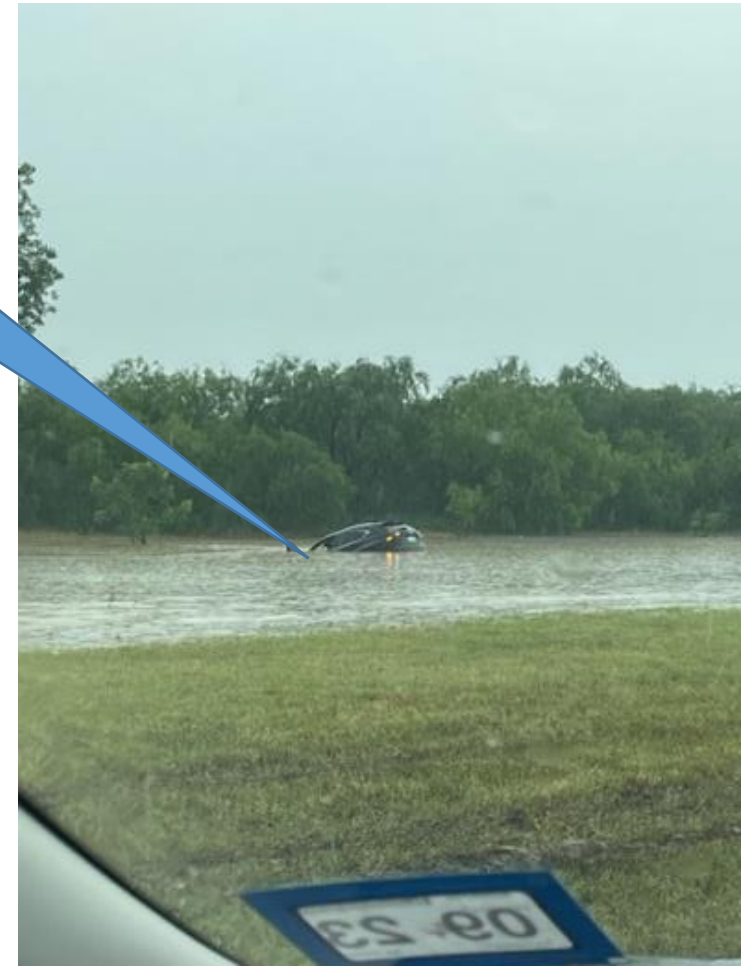

- Existing East Culvert



- Existing West Culvert



Project Scope

To mitigate stormwater overtopping the roadway:

- Re-align the roadway to relocate it away from the creek and raise the roadway.
- Construct channel improvements to include:
 - New culvert under Williams Road
 - Eliminate the crossings on Randol Mill
- Add underground stormdrain lines for the roadway drainage

Other Improvements:

- Sidewalks
- New Water & Sewer Lines
- Franchise Utilities adjustments
- Trail Improvements at Mallard Cove Park
- Adding center turn lane to roadway section

Project Scope

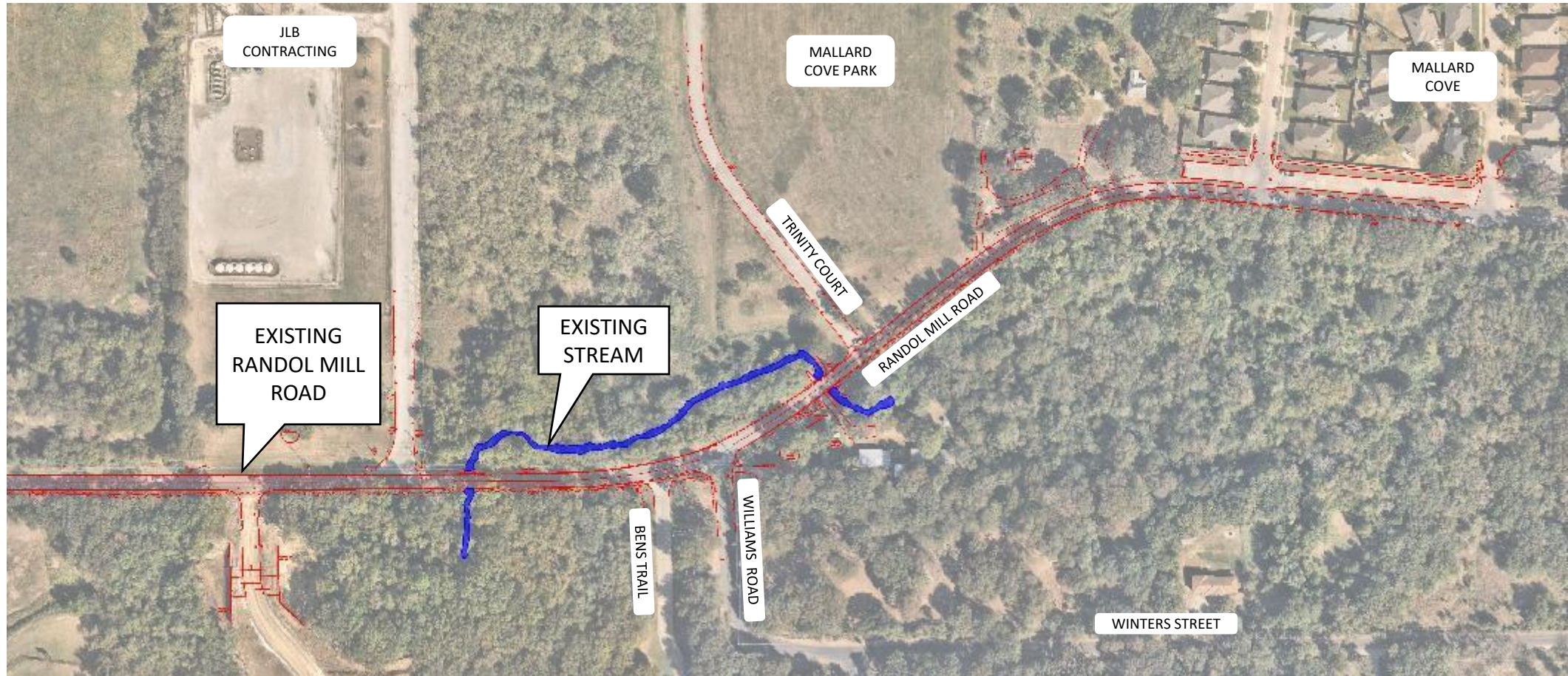

- Red – Existing Road
- Blue – Existing Stream

Project Scope

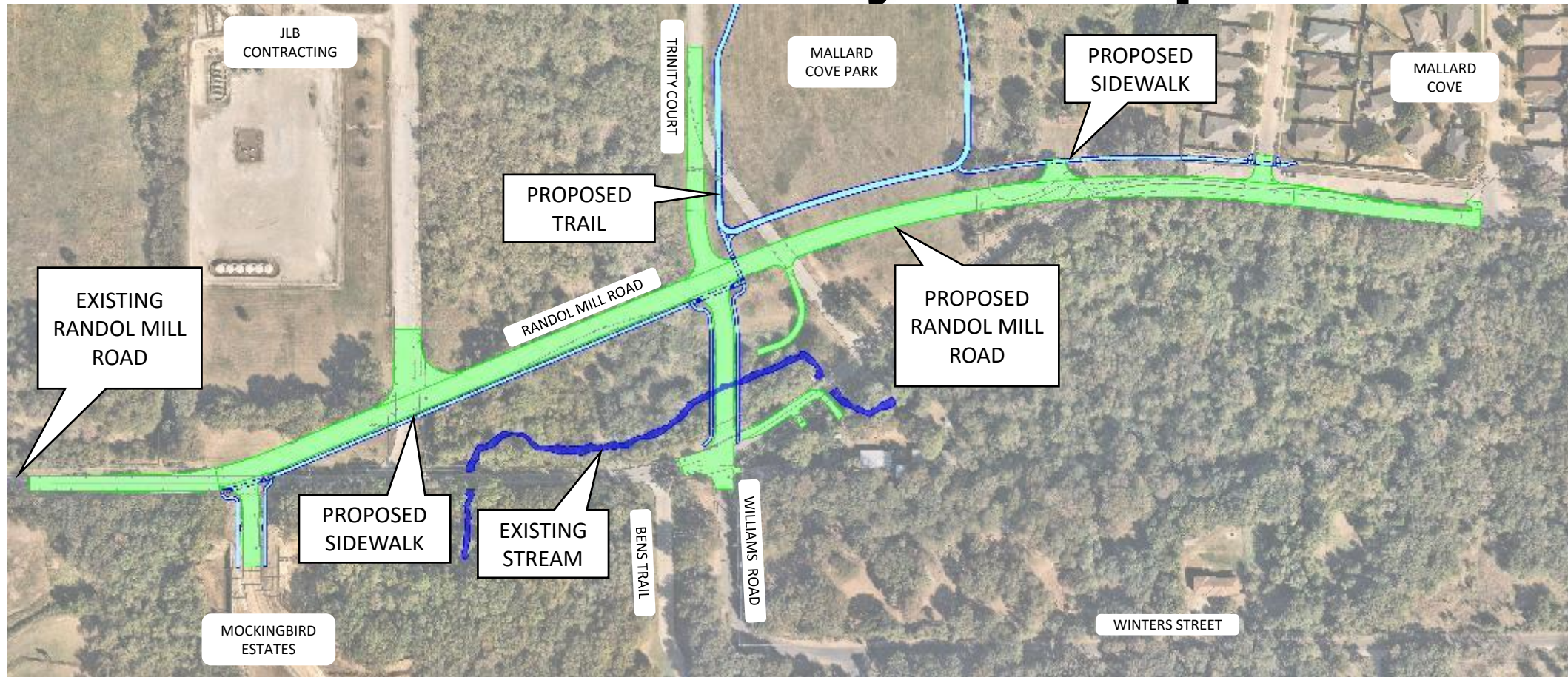

- Green – Proposed Road
- Blue – Proposed Sidewalk and Trail

Project Scope

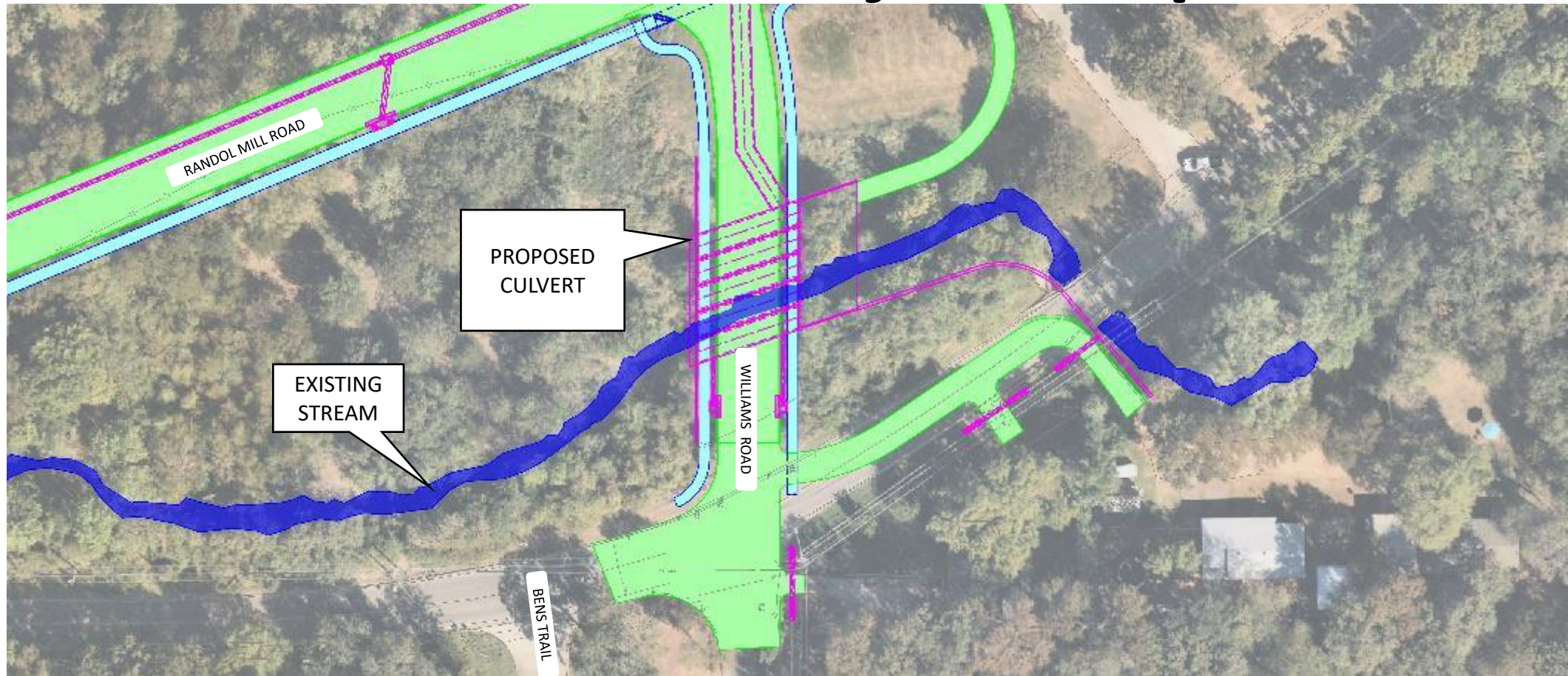

- Purple – Proposed Culvert

Project Scope

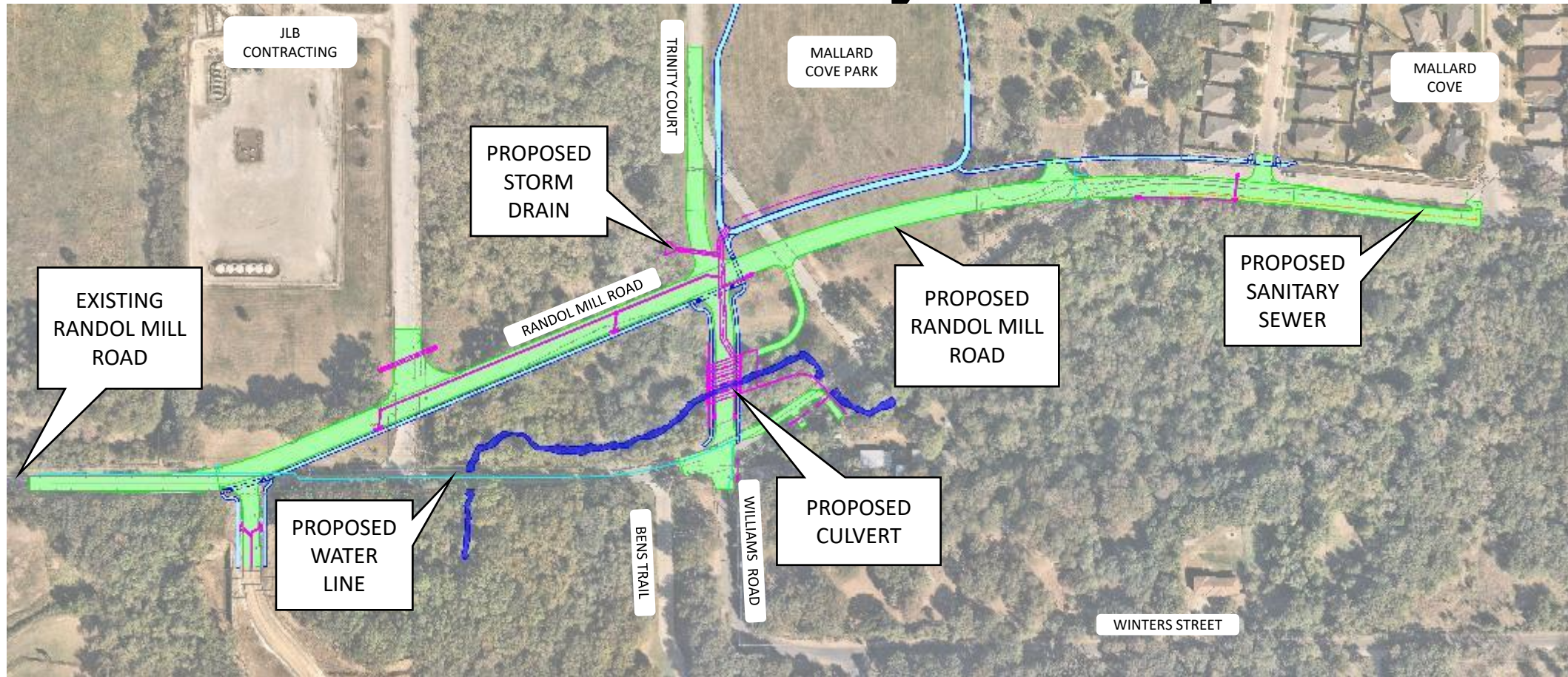

- Cyan – Proposed Water Line
- Orange – Proposed Sewer
- Purple – Proposed Storm Drain and Culvert

Project Scope



Currently Proposed Section
for this project

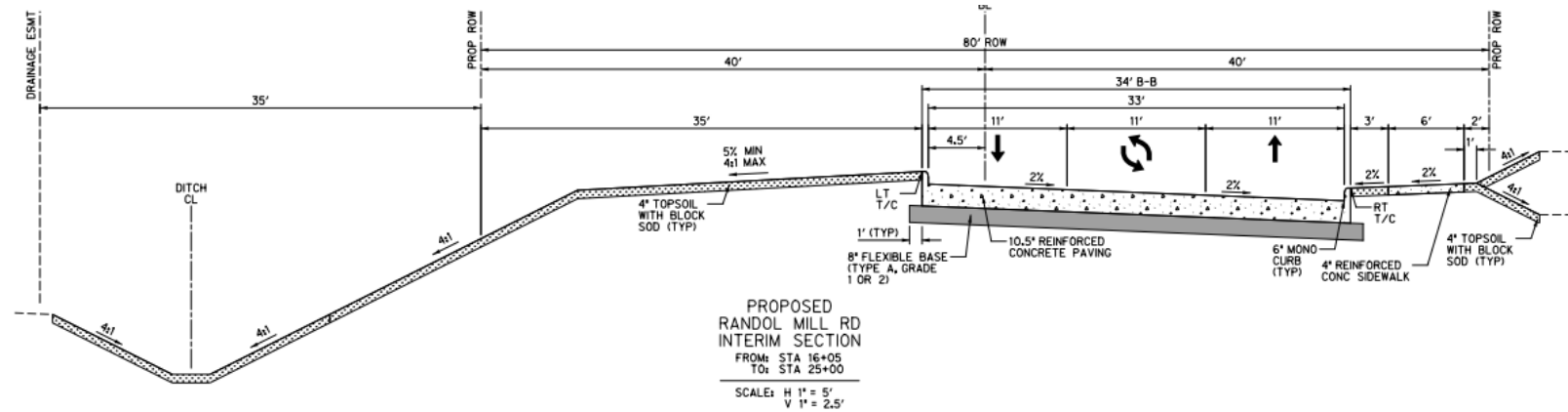

Future Section

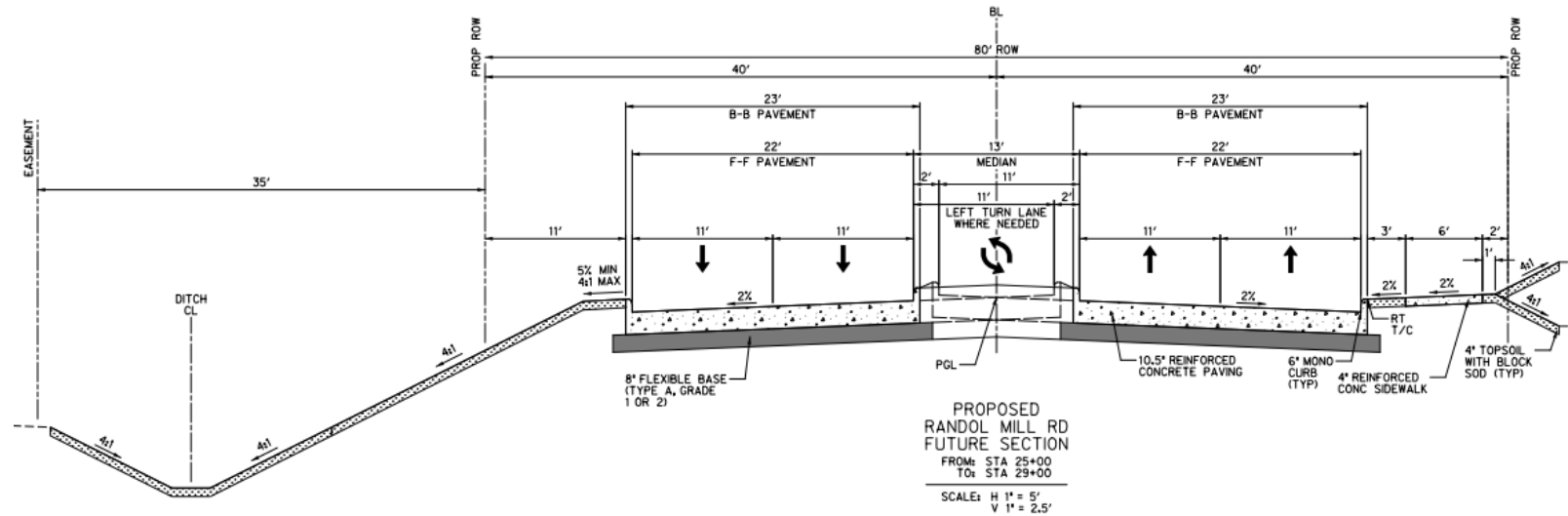

Project Details

Anticipated Project Schedule

- Design Complete – Spring 2024
- Utility Relocation Complete Fall 2024
- Bid – Winter 2024
- Award Construction Contract – Spring 2025
- Construction Start – Spring 2025
- Construction Complete – Summer 2026

Funding

- Stormwater Revenue Bond & Paygo Funds
- Estimated Construction Cost \$8.8 Million

Project Manager – Berton Guidry, PE, CFM

(817) 253-1968

Berton.Guidry@fortworthtexas.gov

Project Website - <https://www.fortworthtexas.gov/projects/cfw-randolmill-hrom>

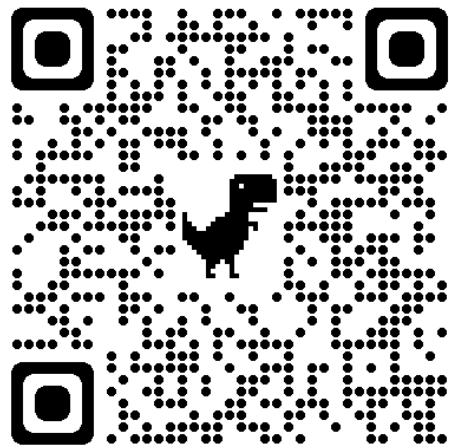

Reporting Made Easy!

- Text HELLO to 817-835-MYFW(6939)
- Online reporting and chat at [fortworthtexas.gov/customer-care](https://www.fortworthtexas.gov/customer-care)
- Call the City Call Center at 817-392-1234

Download the App!



Google Play and the Google Play logo are trademarks of Google LLC.